



# New style pumping station for flood control

## 「 PUMP GATE SYSTEM 」

12 Mar, 2026

# Submersible Pumps for Flood Control

## PUMP GATE SYSTEM

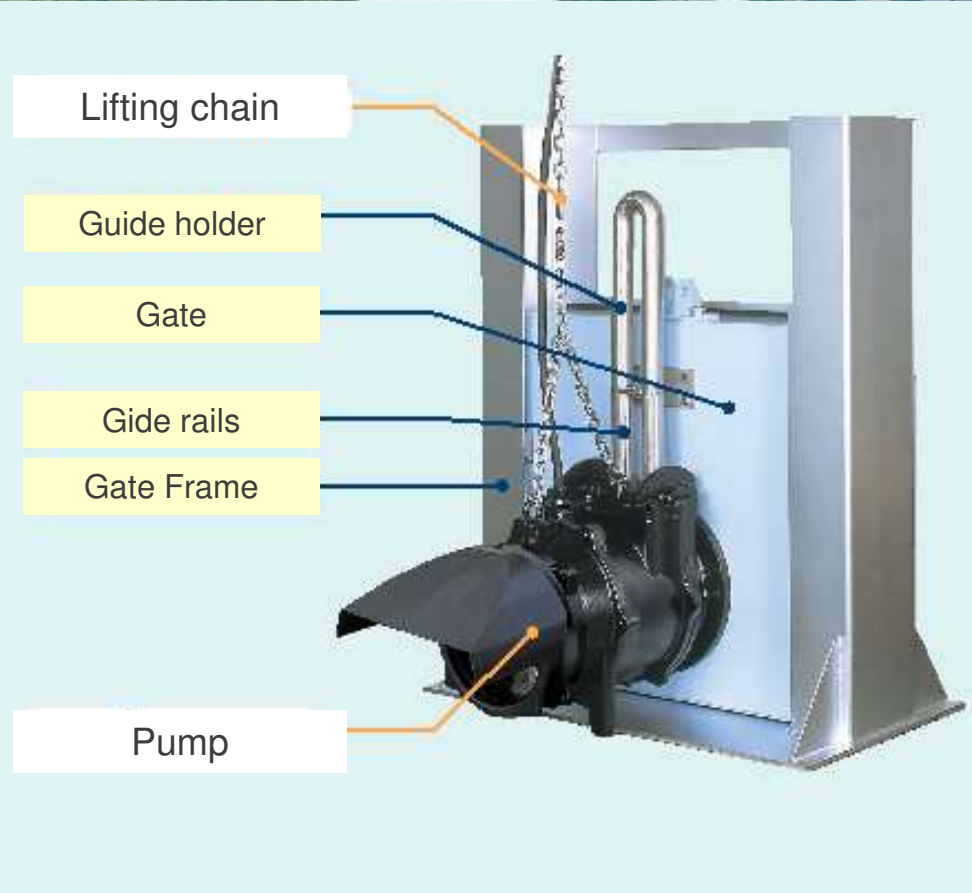
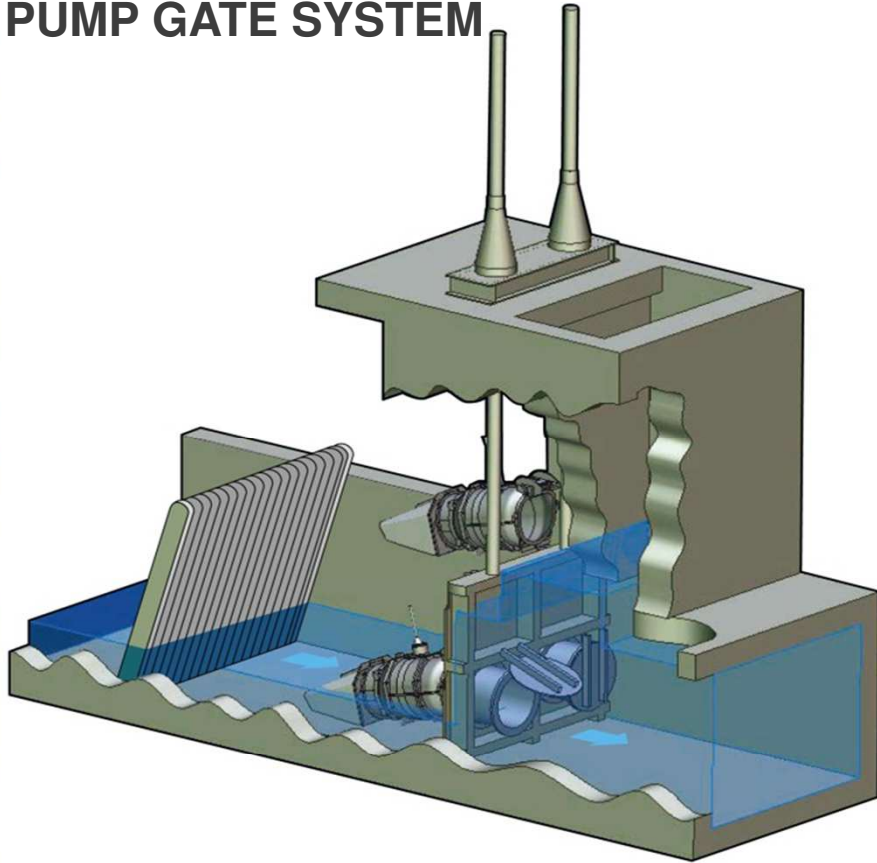

# **1. About ShinMaywa Group and Fluid business segment**

# Company Profile

<b>Corporate Name</b>	ShinMaywa Industries, Ltd.
<b>Head Office</b>	1-1 Shinmeiwa-cho, Takarazuka, Hyogo, Japan
<b>Number of Employees</b>	Consolidated: 6,040, Non-consolidated: 3,136 (as of March 31, 2023)
<b>Established</b>	February 1, 1920



 **Aircraft**



 **Special Purpose Trucks**



 **Water Treatment Equipment**



 **Industrial Machinery Systems**



 **Parking Systems**

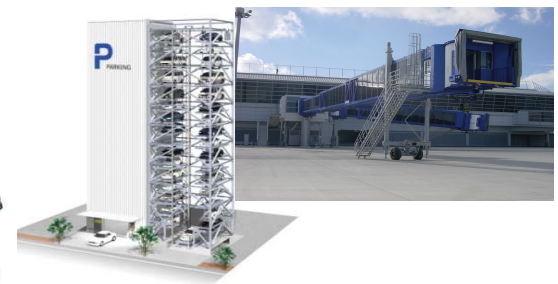

# Variety lineup of wastewater treatment equipment

## Total Solution offered by ShinMaywa Group

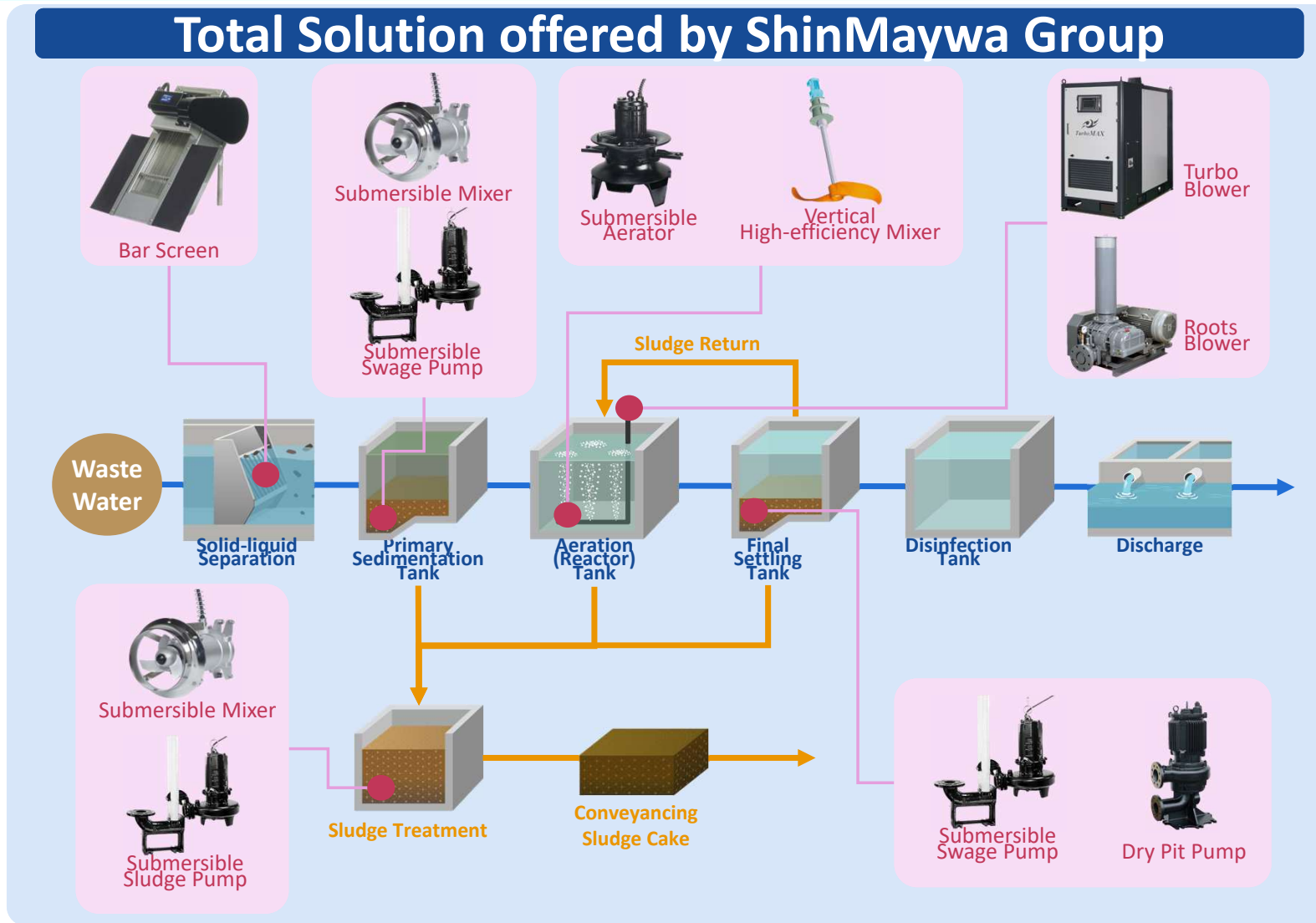

# Group of Fluid business

The image features a world map at the top with orange arrows pointing from a central point in East Asia to various regions including Europe, Africa, and South America. Below the map are three photographs of industrial facilities: an aerial view of a large water treatment plant, a modern multi-story office building, and another aerial view of a large industrial complex. Below these photos are three columns of product information, each with a title, location, and a list of equipment types.

**Thai ShinMaywa Co., Ltd.**  
@ Omnoi, Samutsakorn, Thailand  
[Water Treatment Equipment]

**TurboMAX Co., Ltd.**  
@ Osong, South Korea  
[Turbo Blower]

**ShinMaywa Industries, Ltd.**  
**Ono Plant**  
@ Hyogo, Japan  
[Water Treatment Equipment]

Submersible Pump    Submersible Ejector    Turbo Blower    Submersible Pump    Submersible Mixer    Roots Blower  
...and more!

More than 170 countries, ShinMaywa has contributed environmental improvement

TurboMAX as ShinMaywa group has No.1 Market share holder with more than 10,000 units supply records

# Our products



【for Thailand】

## Apartment Lift Station El Monte, CA

### Reduce Clogging Problem

Non-Clog Pump (2HP)		Grinder Pump (2HP)		CNWX (3" Solid Size, 2HP)	
Problem	Clogging <b>Every Month</b>	Grinder pump installation did not reduce clogging.		<b>No Clogs since Jan. 2011.</b>	
Debris	Feminine sanitary product, Rag, etc.	Grinder Pump Clogging with Rag		CNWX	









【 for Vietnam 】

【 Pumping station in USA 】

# Impeller Line up of Submersible sewage pumps

Technology of ShinMaywa Impeller

Propose optimum model for variety application

	CNWX	CNMJ	CN/CNH	CJ	CV,CVC,CVM	CW
Impeller						
Shape of impeller	Non clog Screw Scroll	Channel with Chopper (3inch Pass trough)	Channel	Channel With chopper	Vortex	Screw
Passage capability	★★★	★★★	★★	★	★★	★★
Cost	★★	★★★	★★★	★★★	★★★	★★
Line Up	Φ65~100 0.75~7.5kW	Φ80~100 1.5~7.5kW	Φ50~800 0.25~250kW	Φ50~100 0.75~7.5kW	Φ40~150 0.25~7.5kW	Φ65-150 1.5~22kW

# Saving Energy in Wastewater treatment plant by Turbo Blower

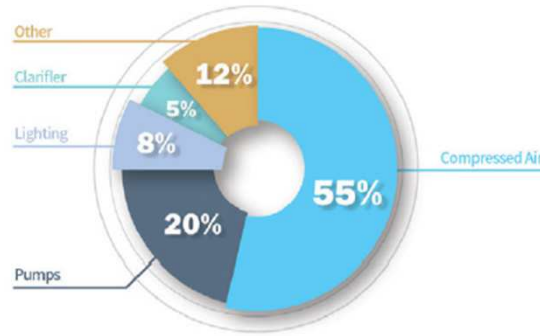

Power Consumption Ratio at Typical Wastewater Treatment Plant

Aeration process uses “50-60%” of total energy consumption in Waste water treatment plant

**136t/year Reduction**



	Traditional Setup	TurboMAX Solution	Change
Blowers	2 (Operation) + 1 (Spare)	1 (Operation) + 2 (Spare)	-25%
Air flow rate (m3/min)	40 + 40 + 0	80 + 0 + 0	Same
Total Power Consumption	125.4kW	95.0kW	Reduce -30.4 kW
Annual power charge	183,084USD	138,700USD	Reduce -44,384 USD

## Saving Energy in Wastewater treatment plant by Turbo Blower

Turbo blowers play an indispensable role in the treatment of wastewater.

TurboMAX provides energy efficiency, low maintenance, compactness and quietness.

Energy Saving

Space Saving

Easy Maintenance

Low Noise

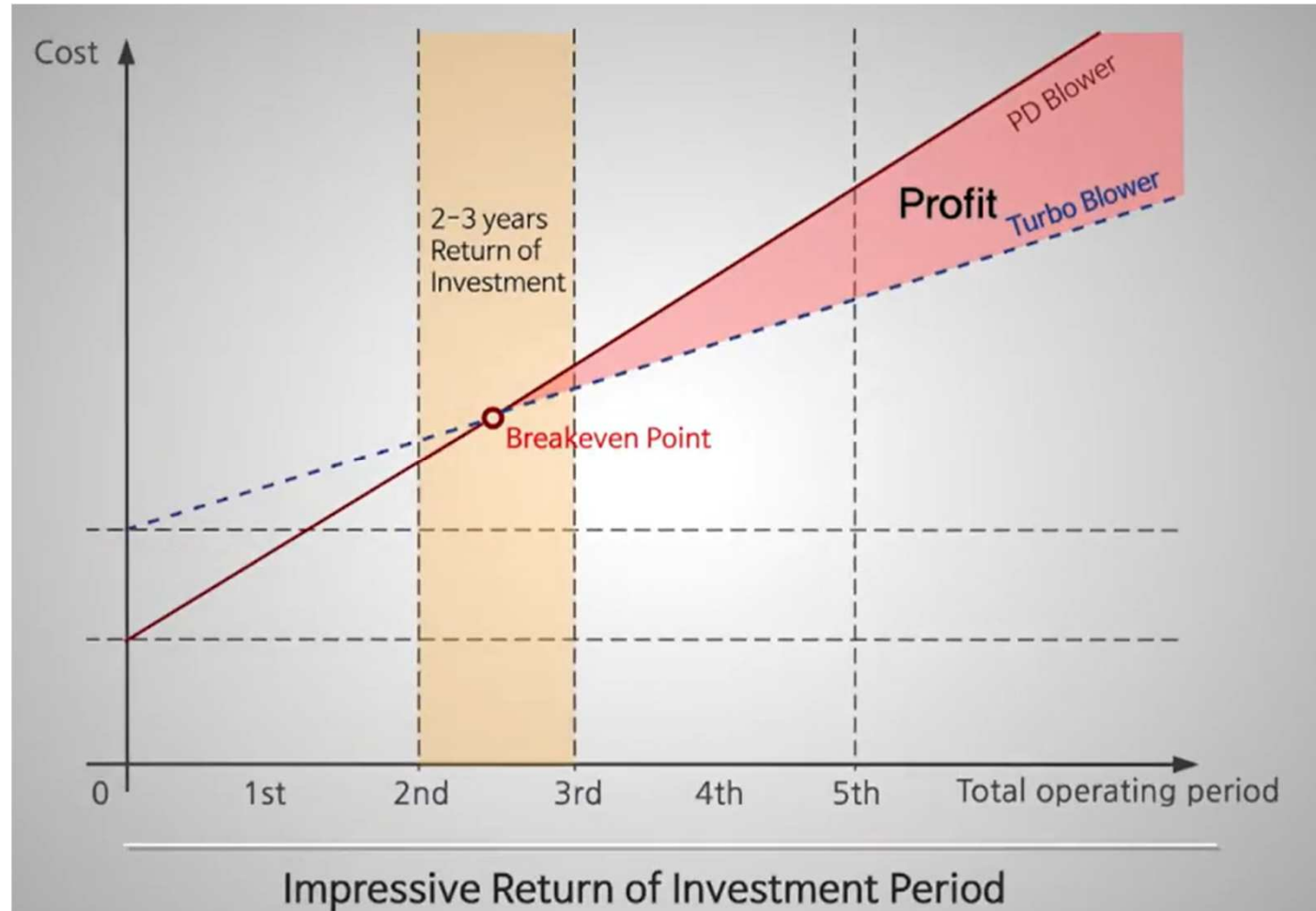

## Our products



## **2. New style of Pumping station for Flood control**

**「 PUMP GATE SYSTEM 」**

# Submersible Pumps for Flood Control

Flooded at the junction area of main river and drainage channel

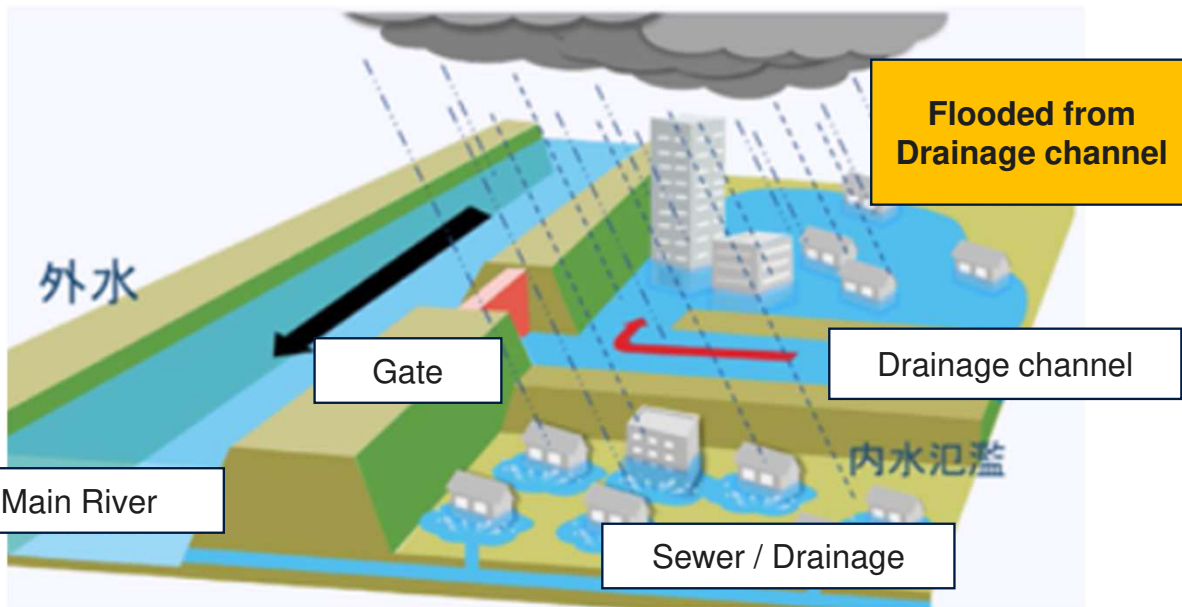

Flooded at the junction area of the drainage channel due to gate close to prevent overflow from the main river

## Conventional Pumping station

Need separately pumping station next to drainage channel

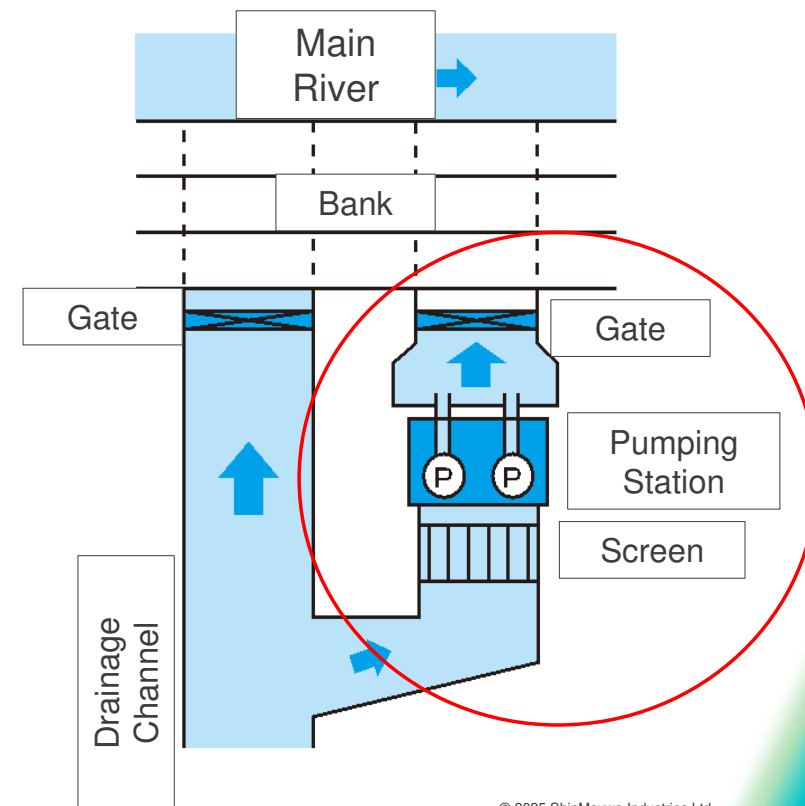

# Submersible Pumps for Flood Control

## Submersible Axial/Mixed Flow Pumps

Available for 3 installation types in both Axial and Mixed flow impeller models.

### Guide rail installation (P-type)

Possible to remove the pump from the tank without pumping out the water.



Instillation Example

### Flange connection (F-type)

Install at the bottom of tank and connect to piping with flange.



### Column installation (C-type)

Just by placing the pump inside the column (pipe), it is automatically aligned and fixed to the base.

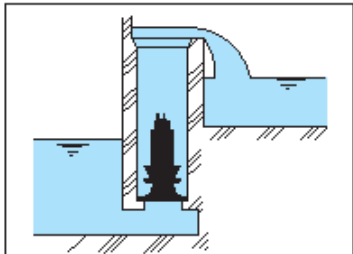

Overflow

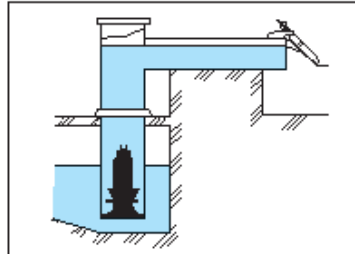

Anti-backflow

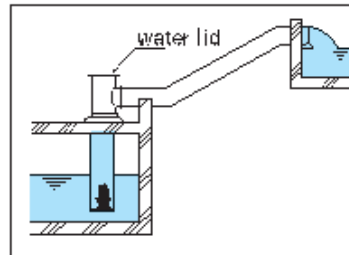

Pressure flow

# Submersible Pumps for Flood Control

Why Pump Gate?

Easy installation, Less construction cost by no machine rooms required.  
Perform both functions of flood gate and pump at the same time.

## PUMP GATE SYSTEM

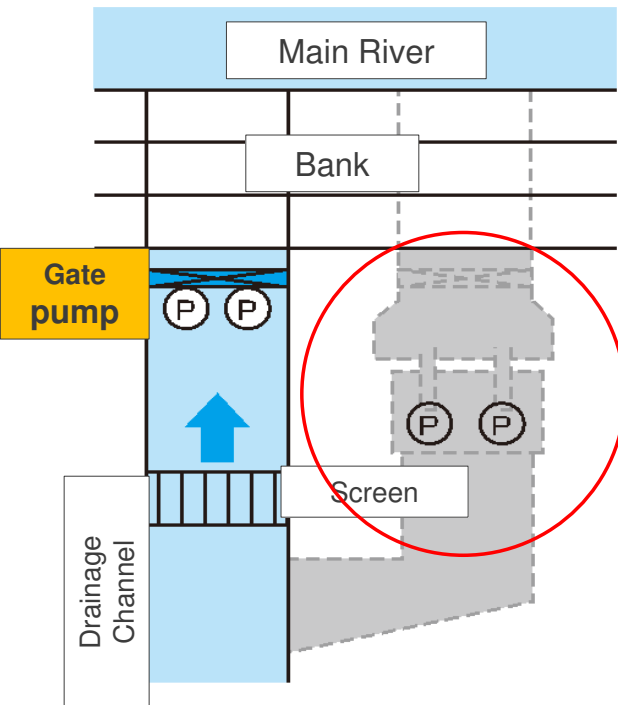

**No need Station Site,  
Machine room for pump**

Saving space

Saving total cost and  
construction period

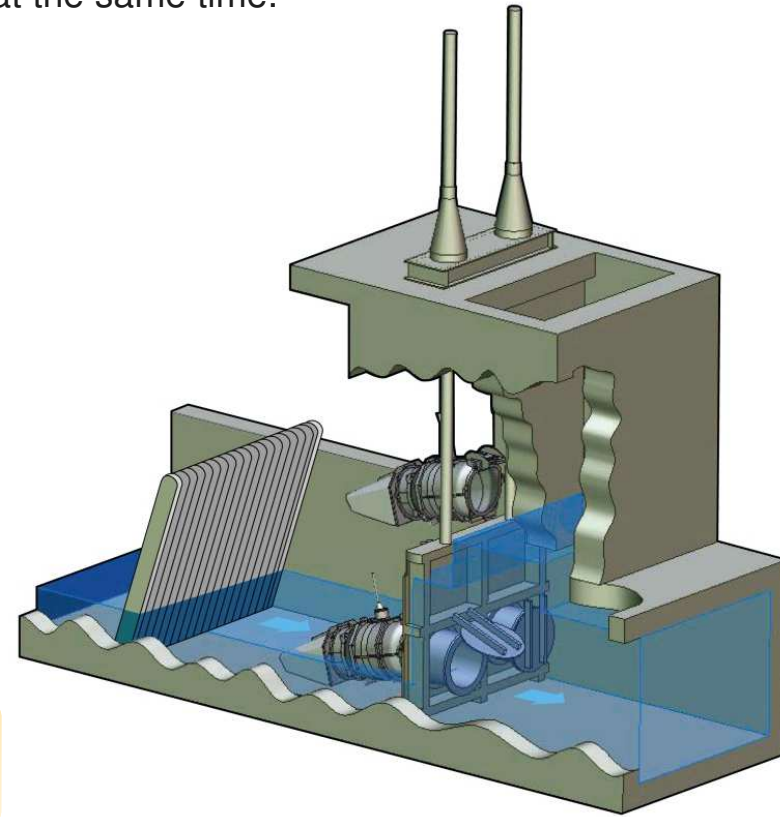

# Submersible Pumps for Flood Control

**ShinMaywa**  
VISION WITH INSIGHT

## ShinMaywa advantage

Auto connecting type makes easy to maintain.  
Low water level operation and natural drainage are also available.

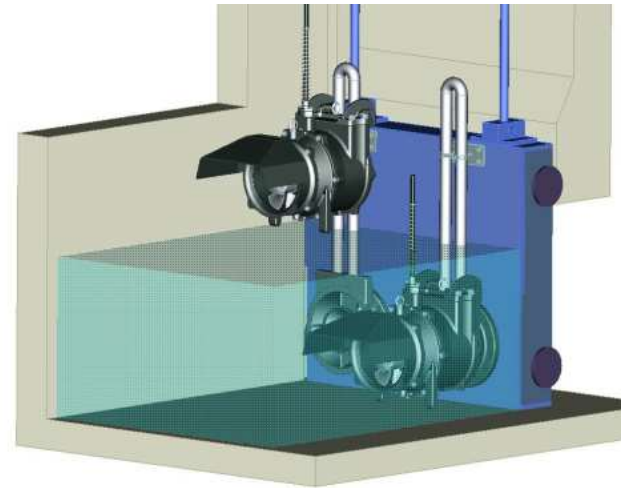
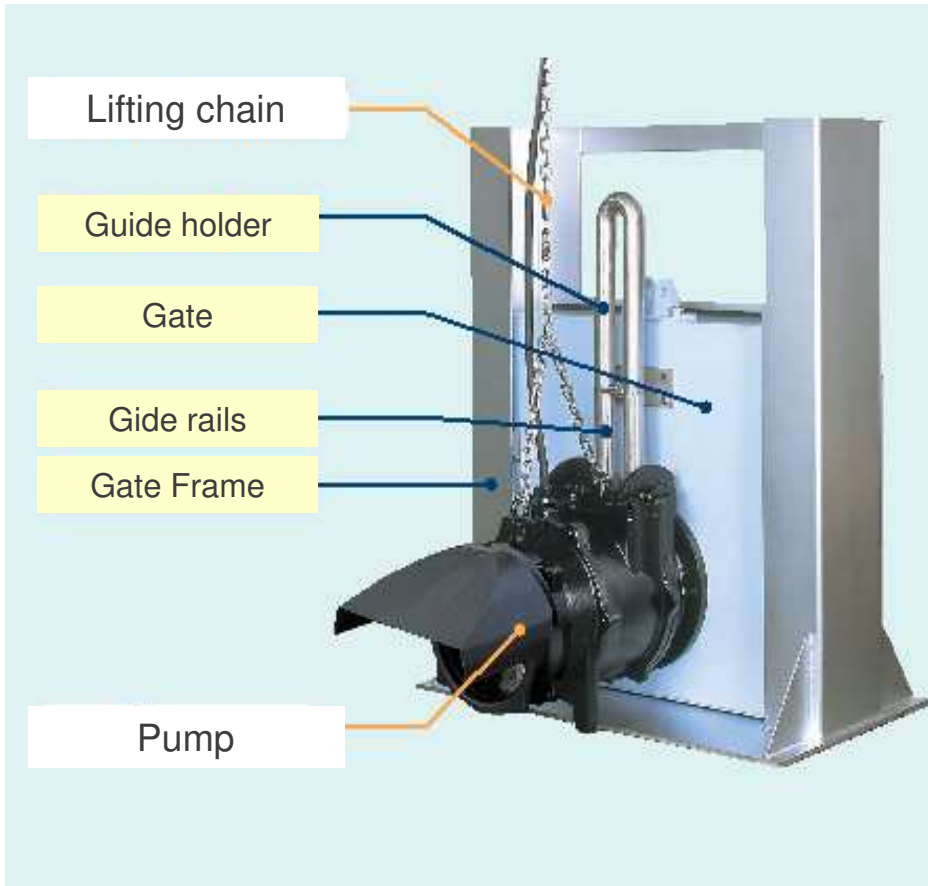

Available to install to gate by lifting chain,  
No need to fix the bolts and nuts.



# Submersible Pumps for Flood Control

ShinMaywa advantage → Applicable for Low water level

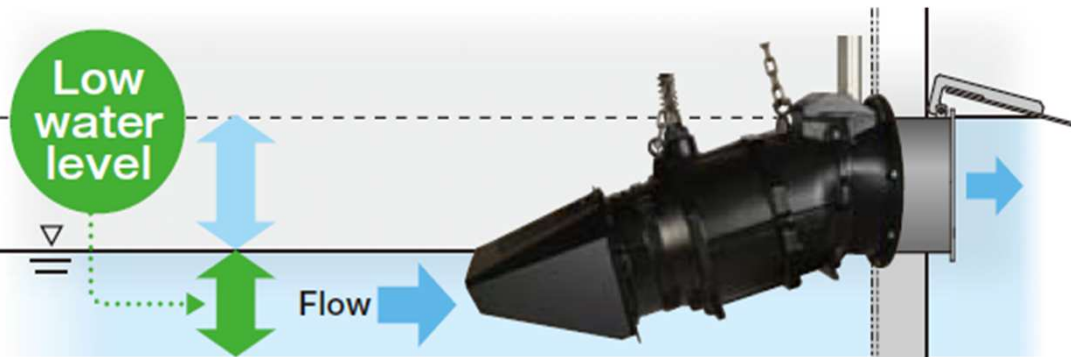

No need additional construction cost for deeper channel

Stable and continuously operation

Half size of discharge diameter (0.5D) is available to operate

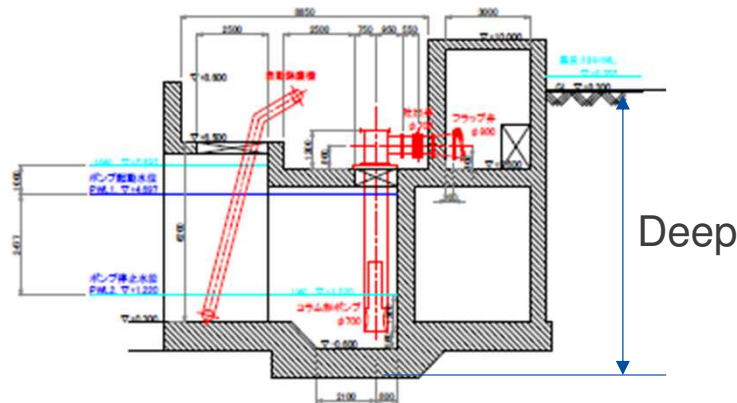

Vertical Pump with Column

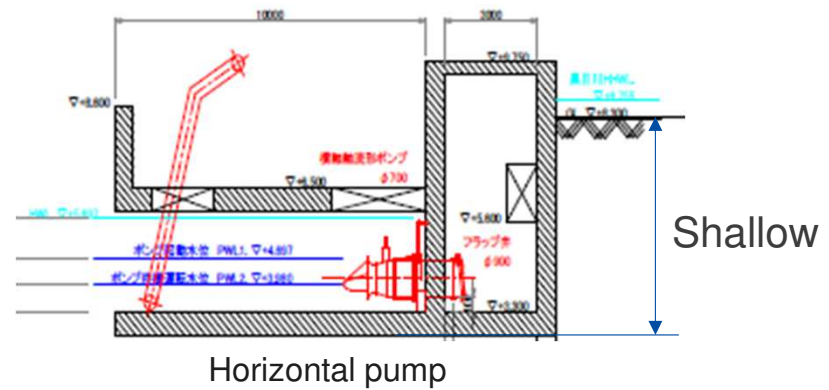

# Submersible Pumps for Flood Control

## Cost Evaluation Image

Cost Item	Conventional	Gate pump	Remarks
Equipment cost (Pump, Control panel etc.)	Almost Same	Almost Same	
<b>Civil Engineering/Construction</b>	<b>Very High</b>	<b>Significant Reduction (Approximately 10-30% compared to conventional systems)</b>	Large concrete structures such as buildings, suction tanks, and discharge tanks are not required.
<b>Land Acquisition</b>	<b>High</b>	<b>Quite less</b>	
Installation	Need long term and High	Short term and Lower	Since pumps are often shipped pre-assembled, on-site construction is minimized, reducing labor costs and significantly shortening construction time.
Maintenance	High	Lower	No building maintenance and easily maintain due to Auto connection of pump

# Submersible Pumps for Flood Control

## Operating principal

Usual



Natural drainage  
And Pump and Gate is lifted

Heavy rain



Gate close



Prevent back flow from main river



Pump start operation with level sensor



Pump stop with level sensor

## Main structure

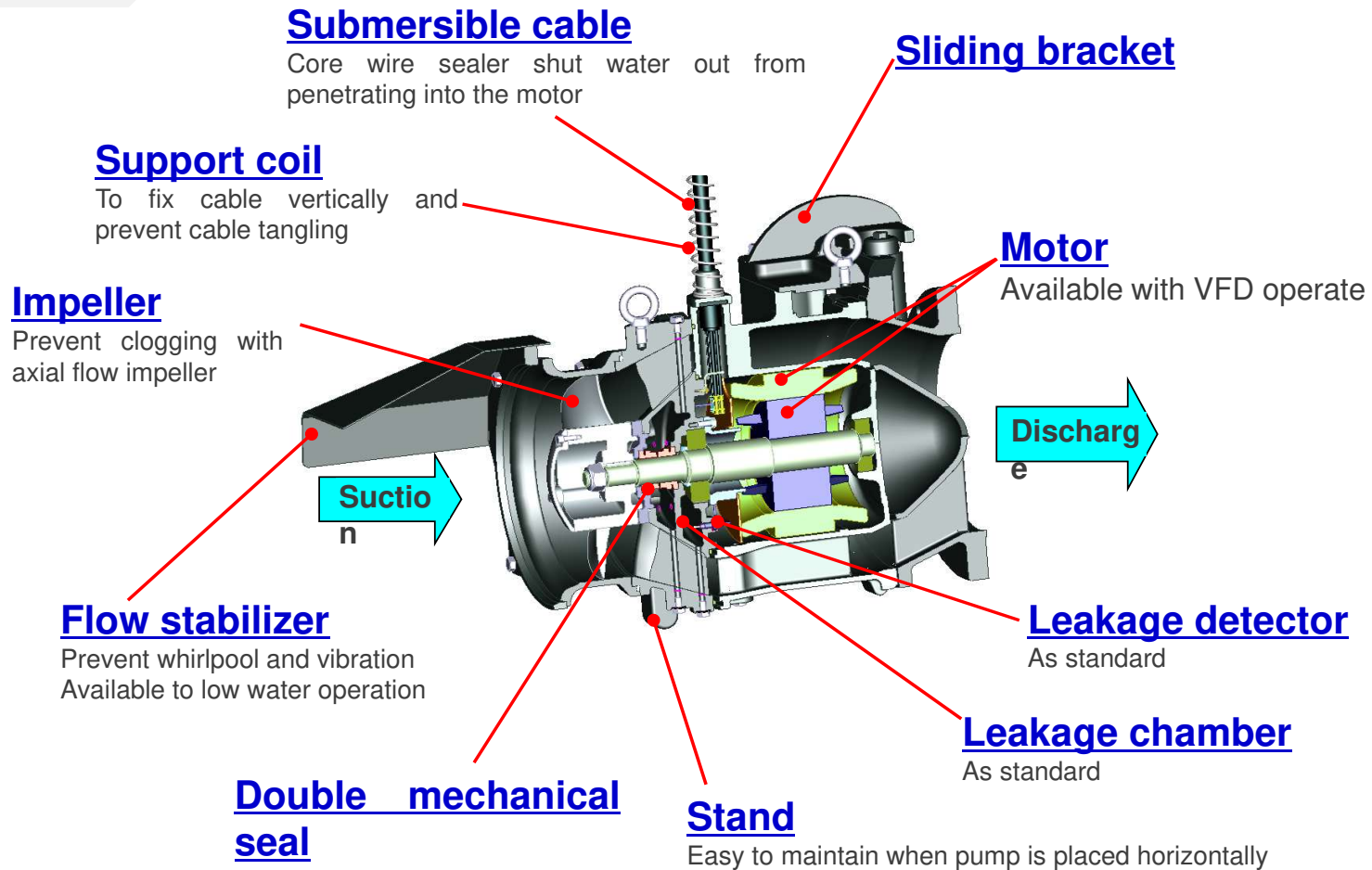

# Submersible Pumps for Flood Control

Performance Curve / SAH-L

Dis.Bore  
(mm)

300

500

700

400

600

800

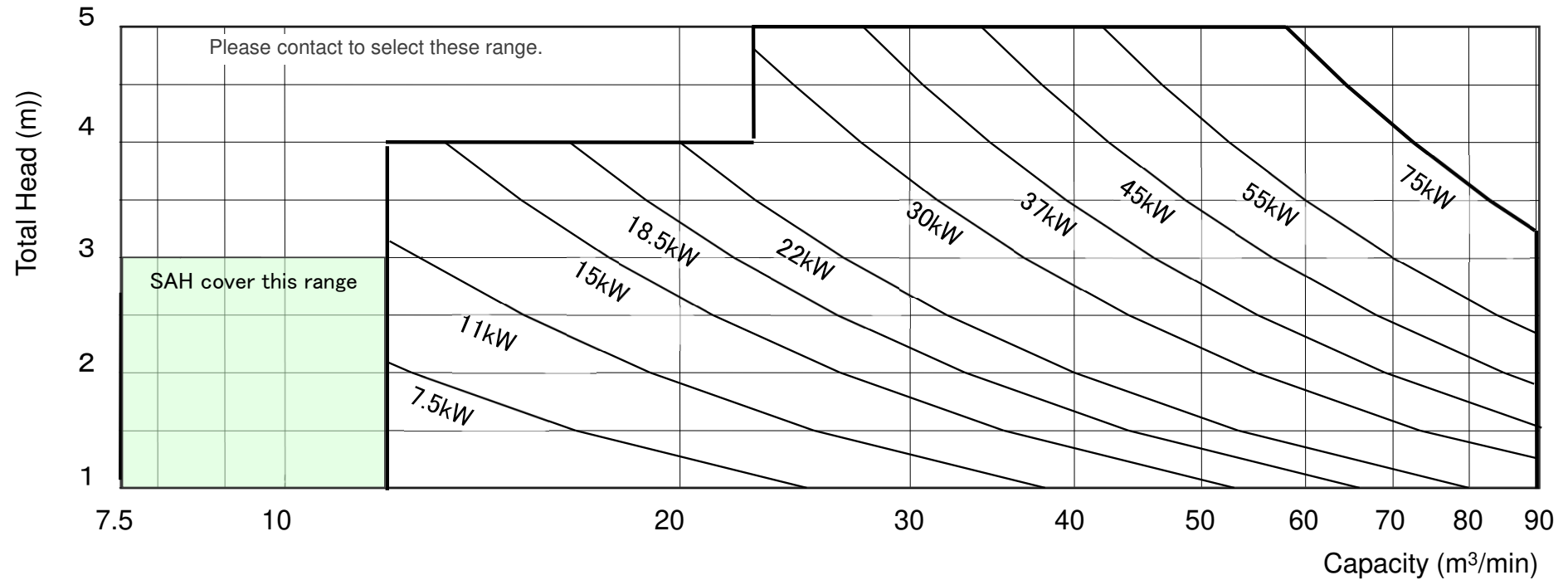

※This curve is for reference. If you need to select detail, please contact us.

# Submersible Pumps for Flood Control

## Sample of Supply Record in Japan

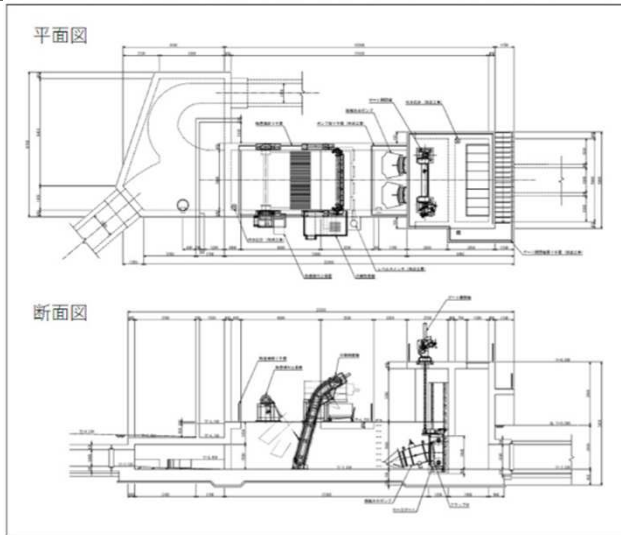

### Tender of Design stage

Municipality



Consultant company



Technical support for  
pump part from  
ShinMaywa

### Tender of construction

Municipality



Civil work



Mechanical and  
Electrical  
By ShinMaywa

## For the NEXT STEP

### Cooperation as a package system

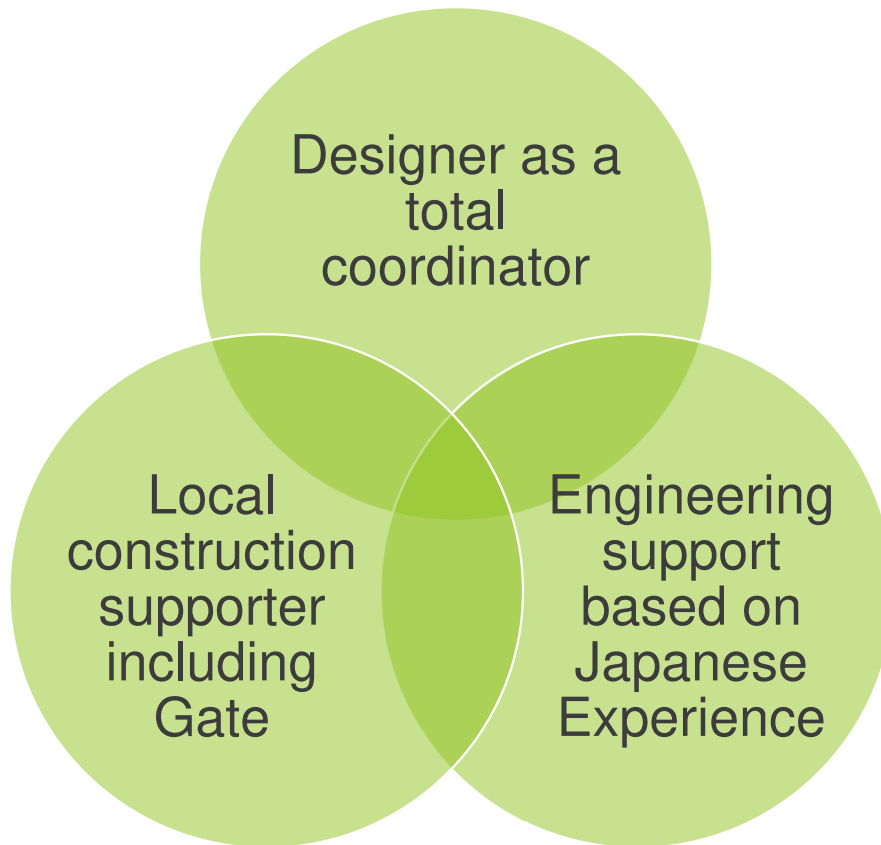

- Mainly experienced in Japan only, ShinMaywa need to study the case of overseas
- ShinMaywa is willing to communicate with design coordinator and local construction partners



---

Contact to

Hisashi Toyohara  
Fluid Div. ShinMaywa Industries,Ltd.

[Email : toyohara.h@shinmawya.co.jp](mailto:toyohara.h@shinmawya.co.jp)